

AKČNÍ NABÍDKA



ORDINACE

Tvrdokovové NÁSTROJE

2024

A-O-24-03

AKČNÍ NABÍDKA

OBJEDNEJ
ON-LINE



Tvrdokovové kuličky SEM/SE

Tvrdokovové finírky



Projit celou >>
nabídku



SEM kuličky - 50%



001 Kulička se zúženým krčkem

	2431R	2432R	2433R	2434R	2435R	2436R	2437R	2438R	2439R	2440R	2441R
bal.	5	5	5	5	5	5	5	5	5	5	5
ø [mm]	1,0	1,2	1,4	1,6	1,8	2,1	2,3	2,5	2,7	2,9	3,1

500 204 001 SEM RA	010	012	014	016	018	021	023	025	027	029	031
--------------------	-----	-----	-----	-----	-----	-----	-----	-----	-----	-----	-----



max. \odot 50 000 min⁻¹

149,-
velikost 010-023

158,-
velikost 025-031

001 Kulička se zúženým krčkem

- prodloužený dřík

	2431RL	2432RL	2433RL	2434RL	2435RL	2436RL	2437RL	2439RL
bal.	5	5	5	5	5	5	5	5
ø [mm]	1,0	1,2	1,4	1,6	1,8	2,1	2,3	2,7

500 205 001 SEM RAL	010	012	014	016	018	021	023	027
---------------------	-----	-----	-----	-----	-----	-----	-----	-----

max. \odot 50 000 min⁻¹

156,-



- perfektní tvar
- zúžený krček umožňuje lepší náhled do preparovaného místa
- preparace bez vibrací



SE kuličky - 50%

OBJEDNEJ
ON-LINE



e-shop >>

001 Kulička

	4232R	2412R	2413R	2414R	2415R	2416R	2417R	2418R
bal.	5	5	5	5	5	5	5	5
ø [mm]	0,8	1,0	1,2	1,4	1,6	1,8	2,1	2,3



500 204 001 SE RA	008	010	012	014	016	018	021	023
-------------------	-----	-----	-----	-----	-----	-----	-----	-----

max. 100 000 min⁻¹

109,-

001 Kulička

- prodloužený dřík

	2412RL	2414rl	2416rl	2418rl
bal.	5	5	5	5
ø [mm]	1,0	1,4	1,8	2,3

500 205 001 SE RAL	010	014	018	023
--------------------	-----	-----	-----	-----

max. 100 000 min⁻¹

131,-



- perfektní tvar
- zúžený krček umožňuje lepší náhled do preparovaného místa
- preparace bez vibrací
- lehká rozpoznatelnost díky zlatému dříku a zelenému proužku

uvedené ceny jsou za kus, po slevě, vč. DPH

KATALOG ORDINACE

3

BLUE LINE



+420 727 959 585



Pro více informací kontaktujte
> obchodního zástupce

Tvrdokovové nástroje - finírky LQ

- 40%

*platí pro všechny velikosti a tvary finírků

164 Špička

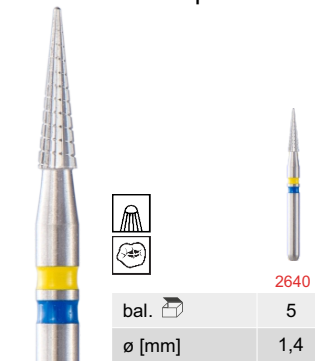

bal.  5
 ø [mm] 1,4

500 314 164 LQ | 014

opt.  300 000 min⁻¹

377,-

165 Špička

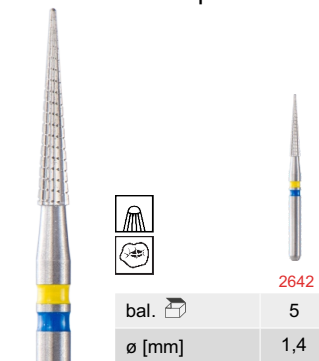

bal.  5
 ø [mm] 1,4

500 314 165 LQ | 014

opt.  300 000 min⁻¹

377,-

249 Plamen



bal.  5
 ø [mm] 1,2

500 314 249 LQ | 012

opt.  300 000 min⁻¹

353,-

243 Plamen špičatý



bal.  5
 ø [mm] 0,9

500 314 243 LQ | 009

opt.  300 000 min⁻¹

353,-



• speciální finírky pro vytváření a přípravu amalgámových výplní

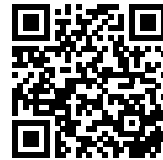

250 Plamen dlouhý

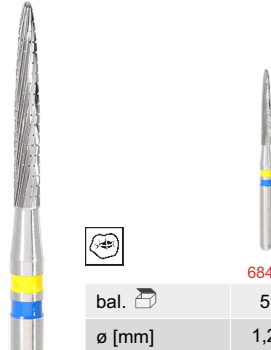

bal.	5
ø [mm]	1,2

6844

500 314 250 LQ	012
----------------	-----

opt. 300 000 min⁻¹

353,-

247 Plamen špičatý



bal.	5
ø [mm]	1,8

2739

500 314 274 LQ	018
----------------	-----

opt. 300 000 min⁻¹

343,-

277 Plamen



bal.	5	5
ø [mm]	1,8	2,3

2747 2748

500 314 277 LQ	018	023
----------------	-----	-----

opt. 300 000 min⁻¹

343,-

198 Kónus zaoblený



bal.	5
ø [mm]	1,6

2697

500 314 198 LQ	016
----------------	-----

opt. 300 000 min⁻¹

377,-

AKCE

uvedené ceny jsou za kus, po slevě, vč. DPH



Tvrdokovové nástroje - finírky

- určené k vyhlazení a vytvarování všech druhů výplní
- nehrozí poškození nebo poškrábání zubní skloviny v mezizubních prostorech

- 40%

*platí pro všechny velikosti a tvary finírků

159 Špička

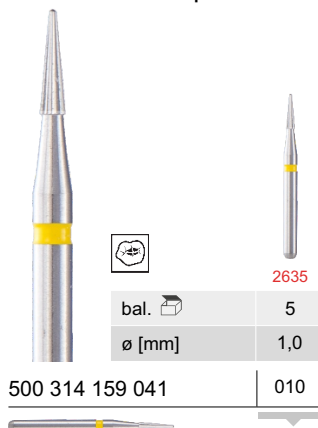

2635

bal.	5
ø [mm]	1,0

500 314 159 041 | 010

opt. 300 000 min⁻¹

325,-

249 Plamen



4938

bal.	5
ø [mm]	1,2

500 314 249 041 | 012

opt. 300 000 min⁻¹

325,-



i ISO 041 = 16 břitů
ISO 042 = 20 břitů

699 Špička



2797

bal.	5
ø [mm]	0,8

500 314 699 041 | 008

opt. 300 000 min⁻¹

377,-



166 Špička

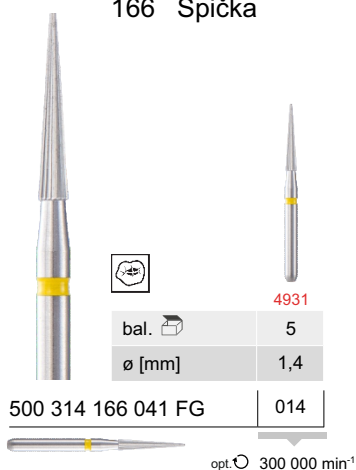

362,-

164 Špička

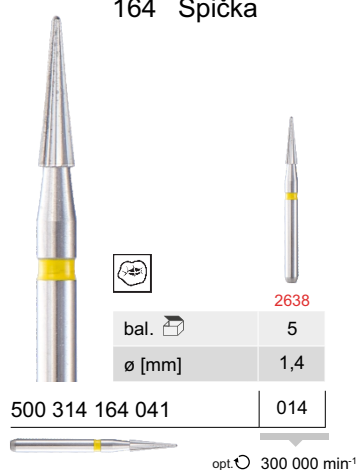

362,-

277 Vajíčko



325,-

274 Plamen



325,-



Tvrdokovové nástroje - finírky

- jemné, jsou určeny na vyhlazení a vytvarování všech druhů výplní
- nehrozí poškození nebo poškrábání zubní skloviny v mezizubních prostorech

- 40%

*platí pro všechny velikosti a tvary finírků

001 Kulička



bal. 	5	5	5
ø [mm]	1,4	1,8	2,3

500 314 001 071	014	018	023
-----------------	-----	-----	-----

opt.  300 000 min⁻¹

500 204 001 071 RA	014	018	023
--------------------	-----	-----	-----

2570R 2571R 2572R

opt.  160 000 min⁻¹

248,-

277 Vajíčko



bal. 	5	5	5
ø [mm]	1,4	1,8	2,3

500 314 277 072	014	018	023
-----------------	-----	-----	-----

opt.  300 000 min⁻¹

500 204 277 072 RA	014	018	023
--------------------	-----	-----	-----

2745R 4934R 4935R

opt.  160 000 min⁻¹

258,-

254 Plamen



bal. 	5	5	5
ø [mm]	1,2	1,4	1,8

500 314 254 072	012	014	018
-----------------	-----	-----	-----

opt.  300 000 min⁻¹

258,-

274 Plamen

bal. 	5	5	5
ø [mm]	1,4	1,6	1,8

500 314 274 072	014	016	018
-----------------	-----	-----	-----

opt.  300 000 min⁻¹

258,-

 ISO 072 = 12 břitů
ISO 071 = 8 břitů



e-shop >>

249 Plamen







bal. 	5
ø [mm]	1,2

500 314 249 072 FG | 012

opt.  300 000 min⁻¹

164 Špička







bal. 	5
ø [mm]	1,4

500 314 164 071 | 014

opt.  300 000 min⁻¹

159 Špička







bal. 	5
ø [mm]	1,0

500 314 159 071 | 010

opt.  300 000 min⁻¹

166 Špička









bal. 	5
ø [mm]	1,4

500 314 166 071 | 014

opt.  300 000 min⁻¹

496 Plamen







bal. 	5	5	5
ø [mm]	0,9	1,0	1,2

500 314 496 071 | 009 | 010 | 012

opt.  300 000 min⁻¹

699 Špička

bal. 	5
ø [mm]	0,8

500 314 699 071 | 008

opt.  300 000 min⁻¹

258,-



Tvrdokovové nástroje - finírky

- určené k vyhlazení a vytvarování všech druhů výplní vyrobených ze světlém tuhacích materiálů
- nehrozí poškození nebo poškrábání zubní skloviny v mezizubních prostorách

- 40%

**platí pro všechny velikosti a tvary finírků*

277 Vajíčko



bal.  5 5 5
 ø [mm] 1,4 1,8 2,3

500 314 277 032	014	018	023
-----------------	-----	-----	-----

opt.  300 000 min⁻¹

500 204 277 032 RA		018	023
--------------------	--	-----	-----

opt.  160 000 min⁻¹

371,-

377,-
(2742R, 2743R)

274 Plamen



bal.  5 5
 ø [mm] 1,6 1,8

500 314 274 032	016	018
-----------------	-----	-----

opt.  300 000 min⁻¹

371,-

166 Špička



bal.  5
 ø [mm] 1,4

500 314 166 031 FG	014
--------------------	-----

opt.  300 000 min⁻¹

377,-

164 Špička



bal.  5
 ø [mm] 1,4

500 314 164 031	014
-----------------	-----

opt.  300 000 min⁻¹

377,-

Tvrdokovové nástroje - finírky

159 Špička

bal.	5
Ø [mm]	1,0

2634

500 314 159 031	010
-----------------	-----

opt. 300 000 min⁻¹

362,-

249 Plamen

bal.	5
Ø [mm]	1,2

2730

500 314 249 032	012
-----------------	-----

opt. 300 000 min⁻¹

371,-

496 Špička

bal.	5
Ø [mm]	0,9

2771

500 314 496 031	009
-----------------	-----

opt. 300 000 min⁻¹

371,-

699 Špička

bal.	5
Ø [mm]	0,8

2796

500 314 699 031	008
-----------------	-----

opt. 300 000 min⁻¹

358,-

i ISO 032 = 30 břitů
ISO 031 = 30 břitů



AKCE

JSME ZÁSTUPCE
KOMET DENTAL
JEDNIČKY NA TRHU
ROTAČNÍCH NÁSTROJŮ

BLUE LINE  +420 727 959 585



Kompletní servis v dodávce rotačních nástrojů
pro stomatologii a laboratoře



Pro více informací kontaktujte
obchodního zástupce

www.rotadent.eu

Rotadent spol. s r.o.
Špidrova 104, 385 01 Vimperk

KONTAKT

Mobil: +420 727 959 585
E-Mail: info@rotadent.eu

 [rotadent_czsk](#)

 [Rotadent spol. s r.o.](#)



AKČNÍ NABÍDKA ORDINACE A-O-24-03