



Rotadent



ROTATING INSTRUMENTS

VÝPRODEJ

vše za 29,-



 Rotadent spol. s r.o.  rotadent_czsk  info@rotadent.eu  +420 388 323 991

Rotadent spol. s r. o. Špidrova 104, 385 01 Vimperk



Grafické značky



Kavitétní preparace









Schůdková preparace



Opracování výplní

Zrnitost



	▶ ultra jemná	494	8 μm
	▶ extra jemná	504	25 μm
	▶ jemná	514	45 μm
	▶ střední	524	107 μm
	▶ hrubá	534	151 μm
	▶ extra hrubá	544	181 μm





Všeobecné informace a návody, jak správně a bezpečně nástroje používat a provádět naleznete na našich stránkách, kde jsou pravidelně aktualizovány.

VR806 314 000 (F511)

001 Kulička

	L [mm]	0,7	2,3	
	10	∅ [mm]	0,7	2,3

R806 314 001 524 FG 007

R806 314 001 544 FG 023

002 Kulička s obloženým krčkem



	L [mm]	3,0	4,0	4,5	
	10	∅ [mm]	1,2	2,1	2,3

R806 314 002 524 FG 012 021 023



010 Obrácený kužel





	L [mm]	1,0	1,2	
	10	∅ [mm]	1,0	1,2

R806 314 010 514 FG 010 012

019 Obrácený kužel s obloženým krčkem







	L [mm]	2,2	2,2	3,0	3,5	3,5	3,5	
	10	∅ [mm]	0,9	1,0	1,2	1,4	1,6	1,8

R806 314 019 524 FG 009 010 012 014 016 018

R806 314 019 534 FG 010 012

032 Dvojité kužel

	L [mm]	1,5	1,5	2,0	
	10	∅ [mm]	1,0	1,2	1,8

R806 314 032 524 FG 010 012 018

038 Dvojité kužel







	L [mm]	4,2	
	10	∅ [mm]	3,3



















R806 314 038 514 FG 033

R806 314 038 544 FG 033

108 Válec krátký











		L [mm]	4,0	4,0	4,0	4,0	4,0
	10	∅ [mm]	1,0	1,2	1,4	1,6	1,8

R806 314 108 514 FG		010	012	014			
R806 314 108 524 FG			012	014	016	018	
R806 314 108 534 FG					016	018	
R806 314 108 544 FG					016		

110 Válec plochý



		L [mm]	6,0	6,0
	10	∅ [mm]	1,0	1,8

R806 314 110 524 FG			018	
R806 314 110 534 FG		010		

111 Válec plochý







	L [mm]	8,0	
	10	∅ [mm]	1,6

R806 314 111 524 FG		016	
---------------------	---	-----	---

129 Válec s ostrou špičkou



	L [mm]	6,0	
	10	∅ [mm]	1,2



R806 314 129 534 FG		012	
---------------------	---	-----	---

29,-

VR806 314 000 (F511)

142 Válec zaoblený



	L [mm]	10,0	
	10	∅ [mm]	1,6

R806 314 142 524	FG	■	■	016
R806 314 142 534	FG	■	■	016

156 Válec plochý



		L [mm]	4,0	4,0
	10	∅ [mm]	1,0	1,4

R806 314 156 524	FG	■	■	014
R806 314 156 534	FG	■	■	010

157 Válec plochý



		L [mm]	6,0
	10	∅ [mm]	1,6

R806 314 157 534	FG	■	■	016
------------------	----	------------------------------------	------------------------------------	-----

158 Válec plochý, dlouhý





		L [mm]	8,0	8,0
	10	∅ [mm]	1,4	1,6

R806 314 158 514	FG	■	■	016
R806 314 158 524	FG	■	■	014
R806 314 158 544	FG	■	■	014

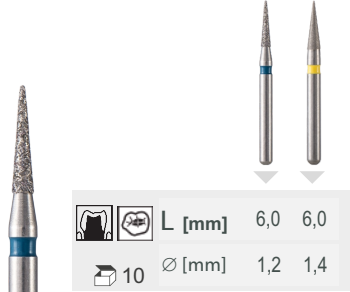
164 Špička krátká







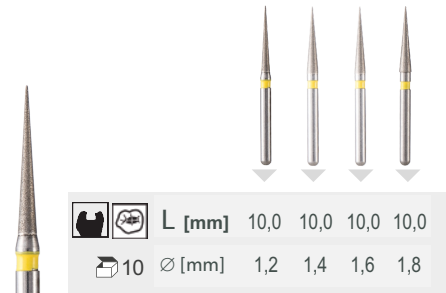

		L [mm]	6,0	6,0
	10	∅ [mm]	1,2	1,4

R806 314 164 504	FG	■	■	014
R806 314 164 524	FG	■	■	012

29,

166 Špička



				L [mm]	10,0	10,0	10,0	10,0
	10	∅ [mm]	1,2	1,4	1,6	1,8		

R806 314 166 504	FG	■	■	012	014	016	018
R806 314 166 514	FG	■	■				018

167 Špička, dlouhá





		L [mm]	11,5	11,5
	10	∅ [mm]	1,2	1,4

R806 314 167 504	FG	■	■	012	014
R806 314 167 524	FG	■	■	012	014

168 Kónus plochý



	L [mm]	3,0	4,0	4,0	
	10	∅ [mm]	1,2	1,4	1,6

R806 314 168 524	FG			014		
R806 314 168 534	FG			016		
R806 314 168 544	FG			012	014	016

172 Kónus plochý



	L [mm]	8,0	
	10	∅ [mm]	1,4

R806 314 172 534	FG		014	
------------------	----	---	-----	---

29,-

173 Kónus plochý



	L [mm]	1,0	
	10	∅ [mm]	1,6

R806 314 173 504	FG		016	
R806 314 173 514	FG		016	

197 Kónus zaoblený



	L [mm]	6,0	6,0	
	10	∅ [mm]	1,0	1,4

R806 314 197 514	FG		010		
R806 314 197 534	FG		010	014	

198 Kónus zaoblený



	L [mm]	8,0	8,0	
	10	∅ [mm]	2,1	2,5

R806 314 198 514	FG		021	025	
R806 314 198 534	FG		021	025	

200 Kónus zaoblený







	L [mm]	11,5	
	10	∅ [mm]	1,4

R806 314 200 524	FG		014	
------------------	----	---	-----	---

213 Kónus špičatý



	L [mm]	11,0	
	10	∅ [mm]	1,6

R806 314 213 524	FG		016	
------------------	----	---	-----	---

220 Kónus zaobl. bez obložené špičky



	L [mm]	10,0	
	10	∅ [mm]	1,4

R806 314 220 514	FG		014	
------------------	----	---	-----	---

233 Hruška



	L [mm]	2,7	
	10	∅ [mm]	1,0

R806 314 233 504	FG		010	
------------------	----	---	-----	---

VR806 314 000 (F511)

234 Hruška, rovné čelo



237 Hruška



238 Hruška, dlouhá



249 Hruška



250 Plamen

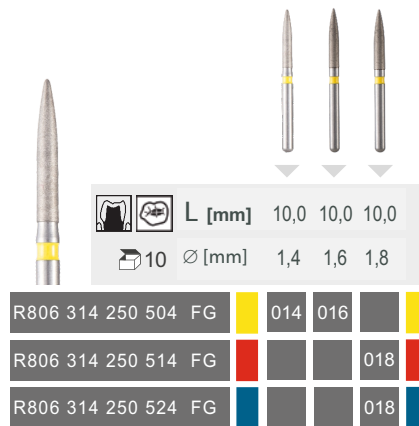

254 Poupě

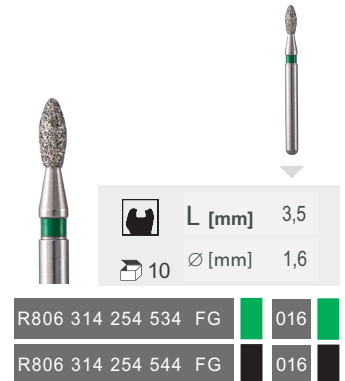

257 Poupě, úzké



277 Vajíčko



278 Vajíčko

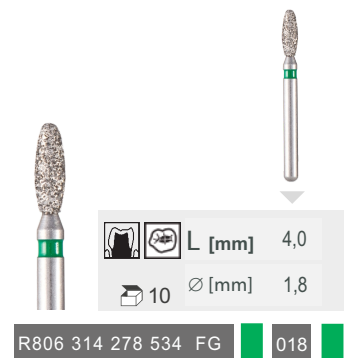

289 Torpédo

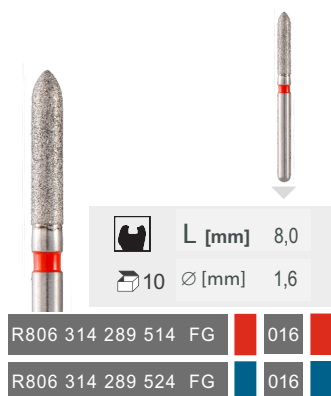

290 Kónus špičatý, dlouhý

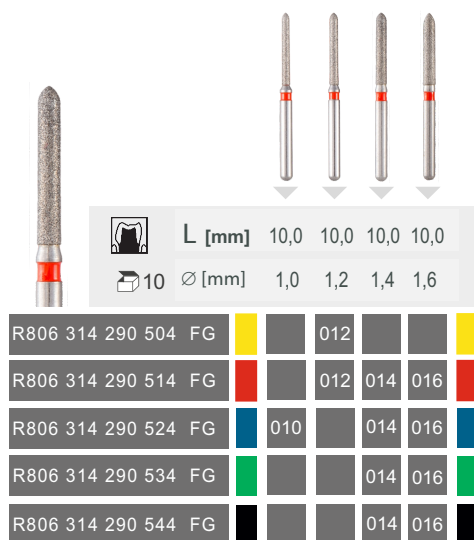

298 Kónus špičatý

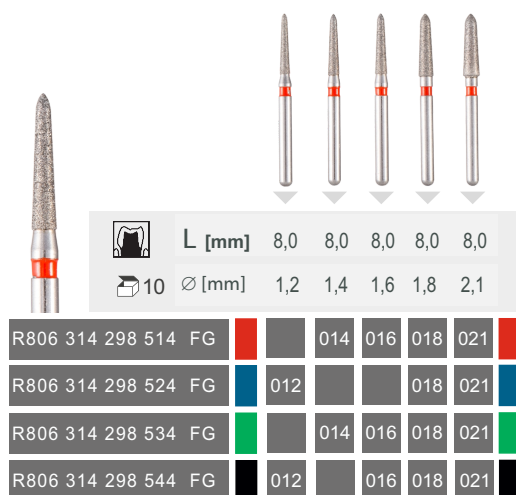

299 Kónus špičatý, dlouhý

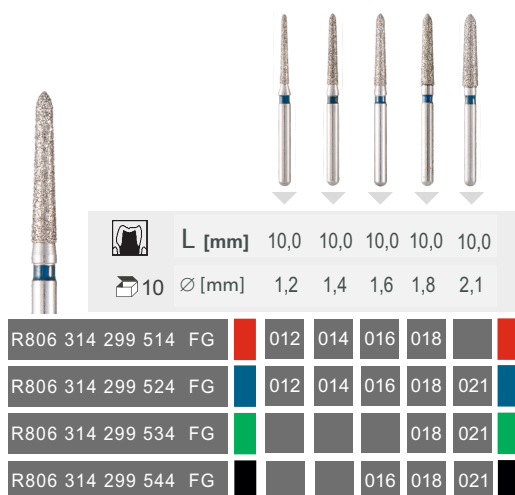

465 Špička



001 Kulička

