



www.rotadent.eu

Rotadent spol. s.r.o.

rotadent_czsk

info@rotadent.eu

+420 388 323 991

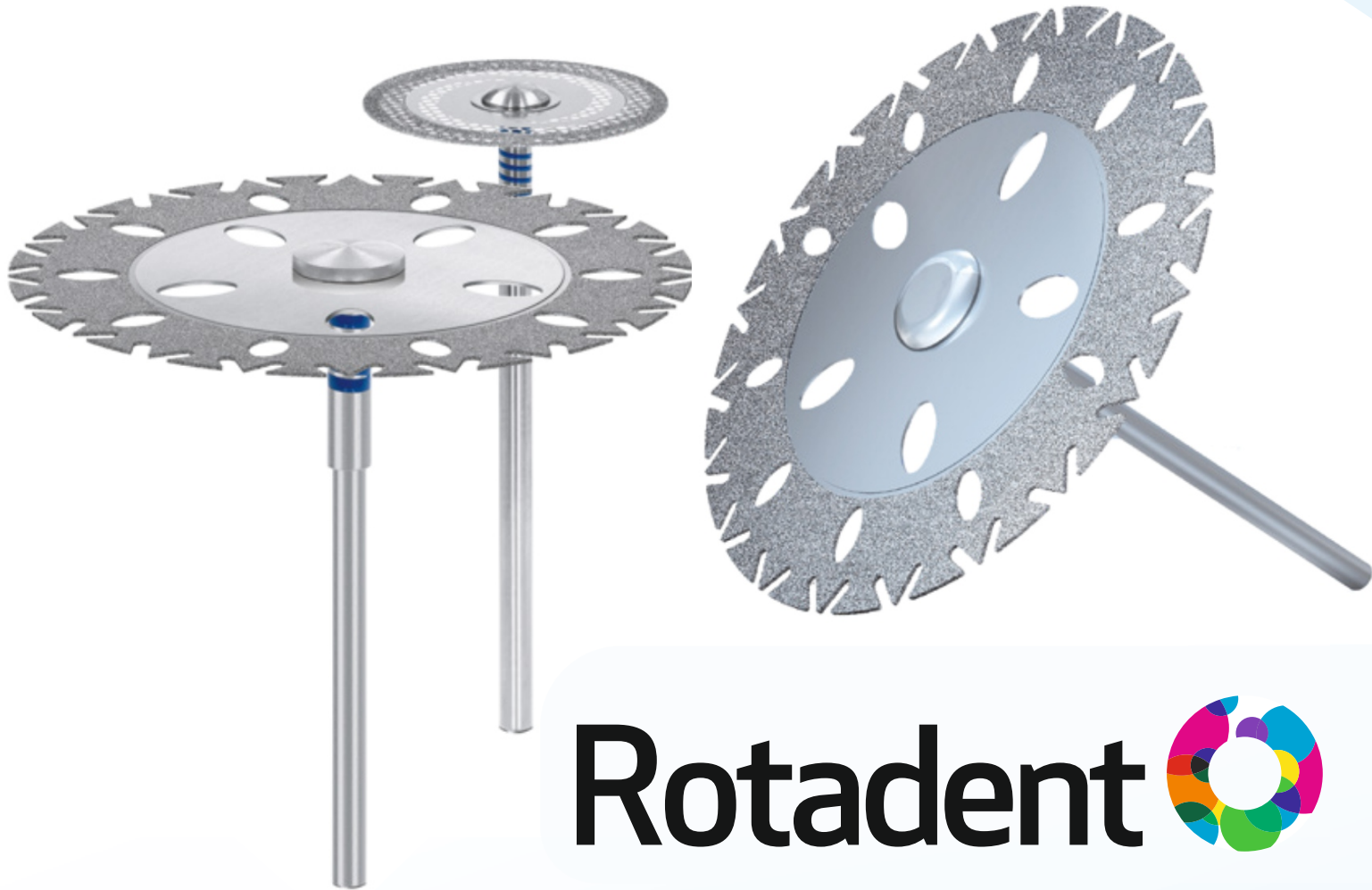

Rotadent

We bring good *shapes* to life

Separáční disky

Produktový katalog

Rotadent spol. s. r. o. Špidrova 104, 385 01 Vimperk

Grafické značky

Celoobložený



Oboustranné obložení

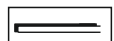

Horní obložení



Spodní obložení

Krajně obložený



Oboustranné obložení

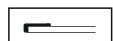

Horní obložení

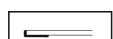

Spodní obložení

Sintrovaný diamant



Krajně sintrovaný



Celosintrovaný



Maximální otáčky

Grafické značky - použití



Rozřezávání sádrových modelů



Opracování korunek a můstků



Opracování pryskyřice



Ortodoncie

Flexibilita

Flex – Flexibilní

Superflex – Superflexibilní

Ultraflex – Ultraflexibilní

Zrnitost

	▶ extra jemná	504	15 μm
	▶ jemná	514	30 μm
	▶ střední /stredná	524	45 μm
	▶ hrubá	534	151 μm



504



514



524



534

OBSAH:

Opracování keramiky

Opracování keramiky, presované keramiky a ZrO keramiky

Rozřezávání sádrových modelů

Všeobecné informace a návody, jak správně a bezpečně nástroje používat a provádět údržbu, naleznete na našich stránkách, kde jsou pravidelně aktualizovány.

Galvanický diamant, separační disk, jemný Flex



REF:	6113	6114
síla[mm]	0,17	0,17
∅ [mm]	19,0	22,0
obložení[mm]	3,0	3,0

806 104 354 511 | 190 | 220

20 000 min⁻¹

Galvanický diamant, separační disk, střední Flex



REF:	6115	6116
síla[mm]	0,25	0,25
∅ [mm]	19,0	22,0
obložení[mm]	3,0	3,0

806 104 354 524 | 190 | 220

20 000 min⁻¹

Galvanický diamant, separační disk, extra jemný Superflex



REF:	9530	4746
síla[mm]	0,14	0,14
∅ [mm]	19,0	22,0
obložení[mm]	3,0	3,0

806 104 355 504 | 190 | 220

20 000 min⁻¹

Galvanický diamant, separační disk, jemný Superflex



REF:	6102	6104	4748
síla[mm]	0,17	0,17	0,17
∅ [mm]	16,0	19,0	22,0
obložení[mm]	3,0	3,0	3,0

806 104 355 514 | 160 | 190 | 220

20 000 min⁻¹

Galvanický diamant, separační disk, hrubý Superflex



REF:	6103	6105	6106
síla[mm]	0,25	0,25	0,25
∅ [mm]	16,0	19,0	22,0
obložení[mm]	3,0	3,0	3,0

806 104 355 524 | 160 | 190 | 220

20 000 min⁻¹

Galvanický diamant, separační disk, hrubý Superflex







REF:	4745	4749
síla[mm]	0,20	0,20
∅ [mm]	18,0	22,0
obložení[mm]	3,0	3,0



806 104 355 534 | 180 | 220

20 000 min⁻¹

Galvanický diamant, separační disk, extra jemný Ultraflex







REF:	6107	6108
 síla[mm]	0,14	0,14
 Ø [mm]	19,0	22,0
 obložení[mm]	3,0	3,0



806 104 355 506  190  220

20 000 min⁻¹

Galvanický diamant, separační disk, jemný Ultraflex







REF:	6109	6110
 síla[mm]	0,17	0,17
 Ø [mm]	19,0	22,0
 obložení[mm]	3,0	3,0



806 104 355 516  190  220

20 000 min⁻¹

Galvanický diamant, separační disk, střední Ultraflex



REF:	6111	6112
 síla[mm]	0,25	0,25
 Ø [mm]	19,0	22,0
 obložení[mm]	3,0	3,0

806 104 355 526  190  220

20 000 min⁻¹

Galvanický diamant, separační disk, jemný Horní obložení

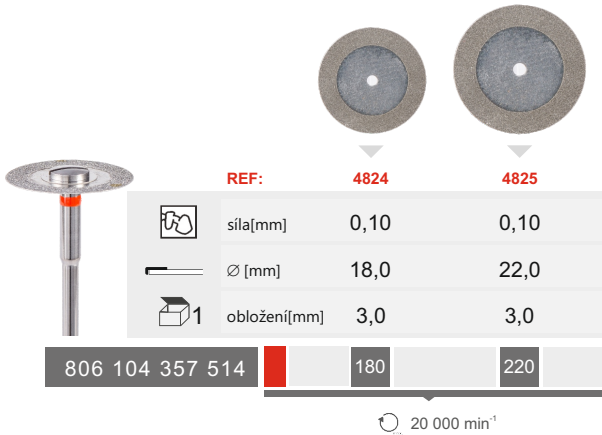

REF:	4824	4825
síla[mm]	0,10	0,10
Ø [mm]	18,0	22,0
1 obložení[mm]	3,0	3,0

806 104 357 514 180 220

20 000 min⁻¹

Galvanický diamant, separační disk, jemný Spodní obložení

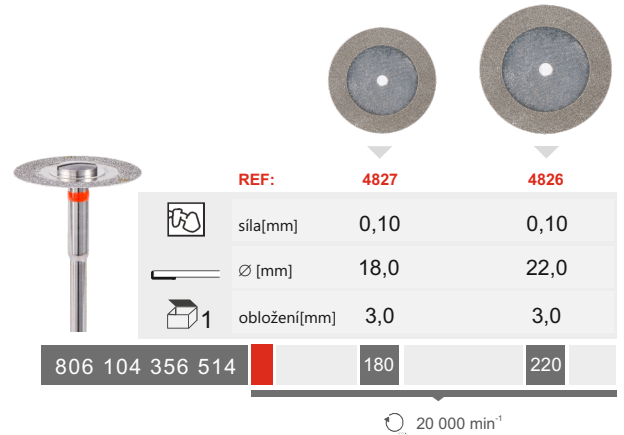

REF:	4827	4826
síla[mm]	0,10	0,10
Ø [mm]	18,0	22,0
1 obložení[mm]	3,0	3,0

806 104 356 514 180 220

20 000 min⁻¹

Galvanický diamant, separační disk, jemný Celoobložený



REF:	4828
síla[mm]	0,18
Ø [mm]	22,0
1 obložení[mm]	6,0

806 104 358 514 220

20 000 min⁻¹

Galvanický diamant, separační disk, střední Celoobložený

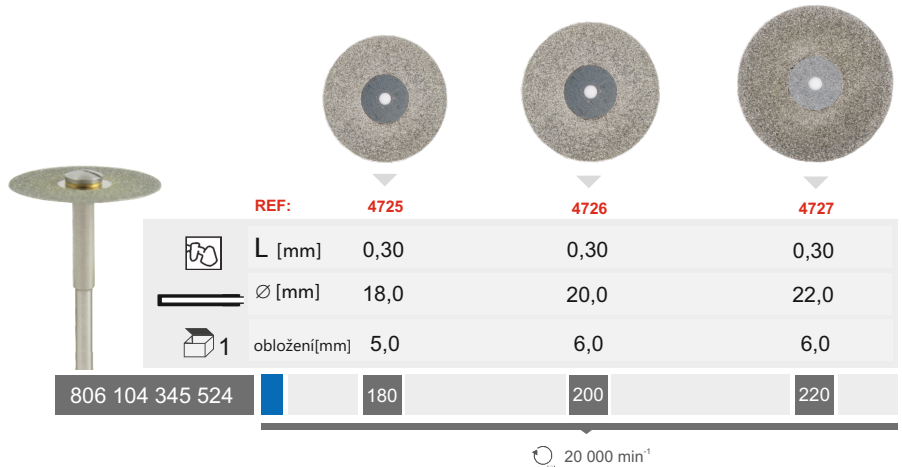

REF:	4725	4726	4727
L [mm]	0,30	0,30	0,30
Ø [mm]	18,0	20,0	22,0
1 obložení[mm]	5,0	6,0	6,0

806 104 345 524 180 200 220

20 000 min⁻¹

Galvanický diamant, separační disk, střední Celoobložený, spodní obložení

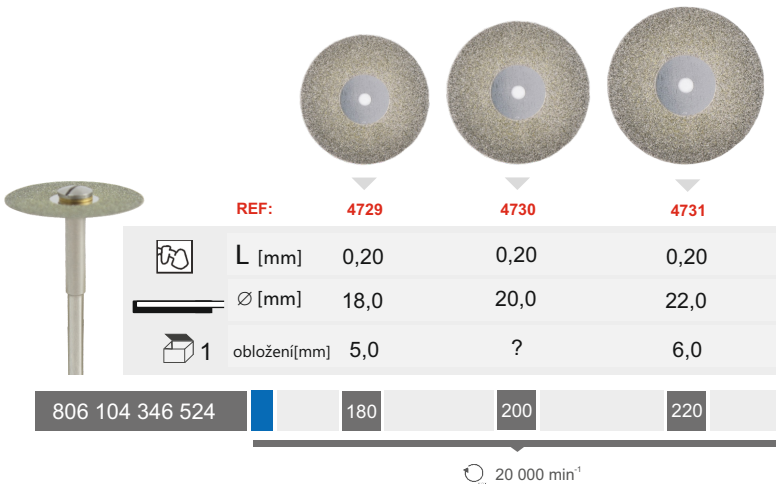

REF:	4729	4730	4731
L [mm]	0,20	0,20	0,20
Ø [mm]	18,0	20,0	22,0
1 obložení[mm]	5,0	?	6,0

806 104 346 524 180 200 220

20 000 min⁻¹

Galvanický diamant, separační disk,
lamelový, jemný
Superflex

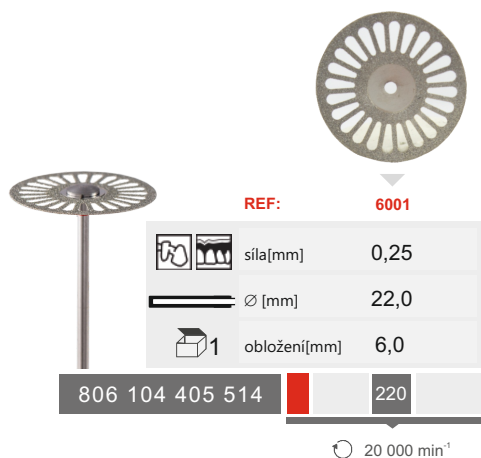

20 000 min⁻¹

Galvanický diamant, separační disk,
lamelový, střední
Superflex

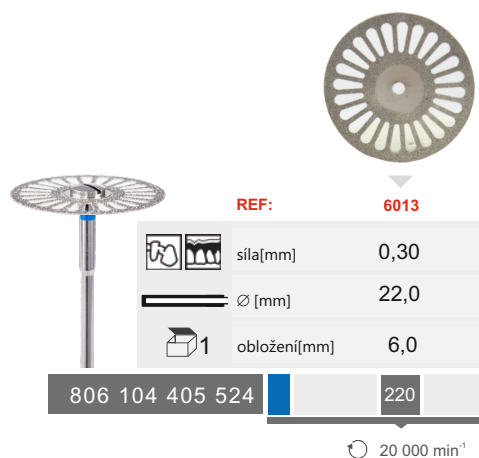

20 000 min⁻¹

Galvanický diamant, separační disk,
perforovaný, extra jemný
Superflex

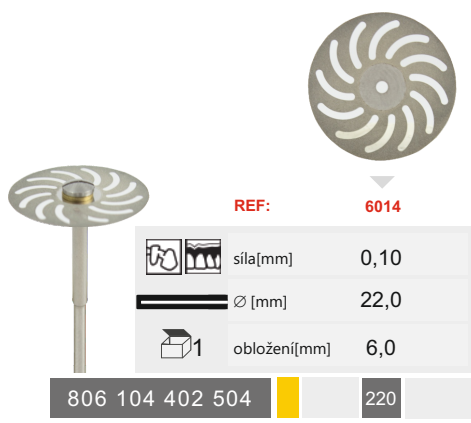

20 000 min⁻¹

Galvanický diamant, separační disk,
perforovaný, jemný
Superflex

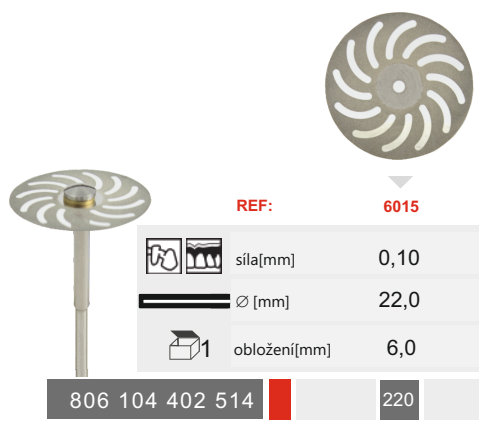

20 000 min⁻¹

Galvanický diamant, separační disk,
perforovaný, jemný
Superflex

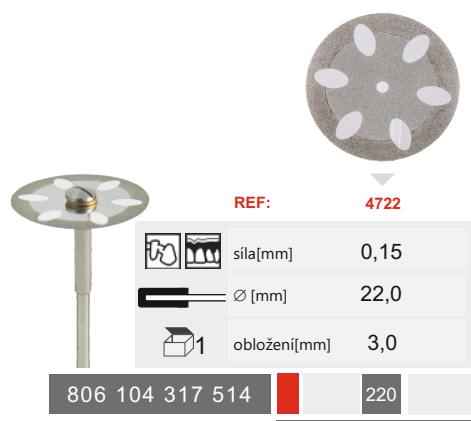

20 000 min⁻¹

Galvanický diamant, separační disk,
perforovaný, hrubý
Superflex

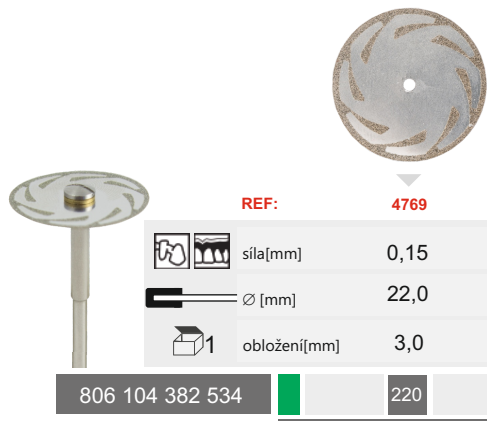

20 000 min⁻¹

Galvanický diamant, separační disk, perforovaný, jemný Superflex



REF:	4912	4913	4914	4915
L [mm]	0,15	0,15	0,15	0,15
∅ [mm]	10,0	14,0	18,0	20,0
1 obložení[mm]	1,0	2,0	3,0	3,0

806 104 400 514 100 140 180 200

44,5 mm 20 000 min⁻¹

104 RA - do rovného násadce



REF:	4912R	4913R	4914R	4915R
806 204 400 514	100	140	180	200

22 mm 20 000 min⁻¹

204 RA - do kolénkového násadce

Galvanický diamant, separační disk, perforovaný, střední Superflex



REF:	4883	4884	4885	4886
L [mm]	0,18	0,18	0,18	0,18
∅ [mm]	10,0	14,0	18,0	20,0
1 obložení[mm]	1,0	2,0	3,0	3,0

806 104 400 524 100 140 180 200

44,5 mm 20 000 min⁻¹

104 RA - do rovného násadce

4885R



REF:	4885R
806 204 400 524	180

22 mm 20 000 min⁻¹

204 RA - do kolénkového násadce

Galvanický diamant, separační disk, perforovaný, hrubý Superflex



REF:	4887	4888
L [mm]	0,22	0,22
∅ [mm]	18,0	22,0
1 obložení[mm]	3,0	3,0



806 104 400 534 180 220

20 000 min⁻¹

- Pro separaci a opracování keramiky, akrylátů a sádky
- Flexibilní s optimální průhledností, vysokým úběrem materiálu a hladkým brusným výkonem

Galvanický diamant, separační disk, střední pevný







REF:	6101	4734
 L [mm]	0,30	0,30
 Ø [mm]	19,0	22,0
 1 obložení[mm]	3,0	3,0

806 104 350 524 | 190 | 220

20 000 min⁻¹

Galvanický diamant, separační disk, střední pevný, spodní obložení



REF:	4736
 L [mm]	0,20
 Ø [mm]	22,0
 1 obložení[mm]	3,0

806 104 351 524 | 220

44,5 mm 20 000 min⁻¹

104 RA - do rovného násadce | 4736R



806 204 351 524 | 220

22 mm 20 000 min⁻¹

204 RA - do kolénkového násadce

Galvanický diamant, separační disk, střední konkávní



REF:	6096
 L [mm]	0,35
 Ø [mm]	19,0
 1 obložení[mm]	8,0

806 104 386 524 | 190

20 000 min⁻¹

Galvanický diamant, separační disk, střední







REF:	4724
 L [mm]	0,30
 Ø [mm]	22,0
 1 obložení[mm]	1,5

806 104 340 524 | 220

20 000 min⁻¹

Galvanický diamant, separační disk, jemný



REF:	4831	4832
 L [mm]	0,20	0,20
 Ø [mm]	18,0	22,0
 1 obložení[mm]	3,0	3,0

806 104 365 514 | 180 | 220

20 000 min⁻¹

Galvanický diamant, separační disk, jemný



REF: 4829 4830 4762

	síla [mm]	0,15	0,15	0,15
	∅ [mm]	6,5	8,0	10,0
	obložení[mm]	1,0	1,0	1,0

806 104 361 514

065 080 100

20 000 min⁻¹

Galvanický diamant, separační disk, jemný



REF: 4904

	síla [mm]	0,15
	∅ [mm]	10,0
	obložení[mm]	3,0

806 104 362 514

100

20 000 min⁻¹

Galvanický diamant, separační disk, střední Oboustranně obložený



REF: 4965 4966

	L [mm]	0,20	0,20
	∅ [mm]	18,0	22,0
	obložení[mm]	3,0	3,0

806 104 358 524

180 220

20 000 min⁻¹

Galvanický diamant, separační disk, hrubý Oboustranně obložený



REF: 4967 4968

	L [mm]	0,22	0,22
	∅ [mm]	18,0	22,0
	obložení[mm]	3,0	3,0

806 104 358 534

180 220

20 000 min⁻¹

Opracování keramiky, presované keramiky a ZrO keramiky

Galvanický diamant, separační disk, střední



REF: 6482

	L [mm]	0,30
	∅ [mm]	19,0
	obložení[mm]	3,0

808 104 355 524

190

20 000 min⁻¹

CAD/CAM Zro2

Galvanický diamant, separační disk, hrubý Diamantový disk k odřezávání ZrO2 korunek a můstků



REF: F407 F408

	L [mm]	0,13	0,13
	∅ [mm]	8,0	10,0
	obložení[mm]	2,0	3,0

806 104 327 514

080 100

20 000 min⁻¹

Galvanický diamant, separační disk, jemný

REF:	9550	9549	4833	4960	4961
L [mm]	0,15	0,15	0,30	0,35	0,35
∅ [mm]	19,0	22,0	30,0	37,0	45,0
obložení[mm]	3,0	3,0	3,0	3,0	3,0
806 104 377 514	190	220	300	370	450

20 000 min⁻¹

Galvanický diamant, separační disk, hrubý

REF:	4955	4956	4958	4959
L [mm]	0,22	0,22	0,32	0,32
∅ [mm]	18,0	22,0	30,0	40,0
obložení[mm]	3,0	3,0	3,0	3,0
806 104 341 534	180	220	300	400

20 000 min⁻¹

Galvanický diamant, separační disk na sádro
jemný, krajně obložený

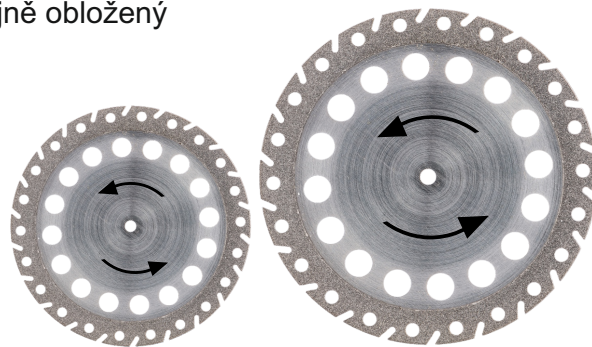

REF: 4960 4961

	L [mm]	0,30	0,30
	∅ [mm]	37,0	45,0
	obložení[mm]	4,0	4,0

806 104 377 514 370 450

20 000 min⁻¹

Galvanický diamant, separační disk na sádro
jemný, krajně obložený

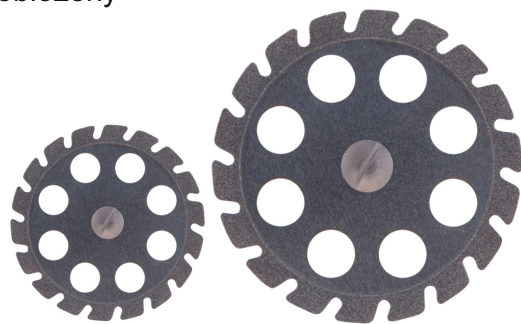

REF: 7566 7567

	L [mm]	0,15	0,15
	∅ [mm]	30,0	45,0
	obložení[mm]	4,0	4,0

806 104 378 514 300 450

20 000 min⁻¹

Galvanický diamant, separační disk na sádro
střední, krajně obložený

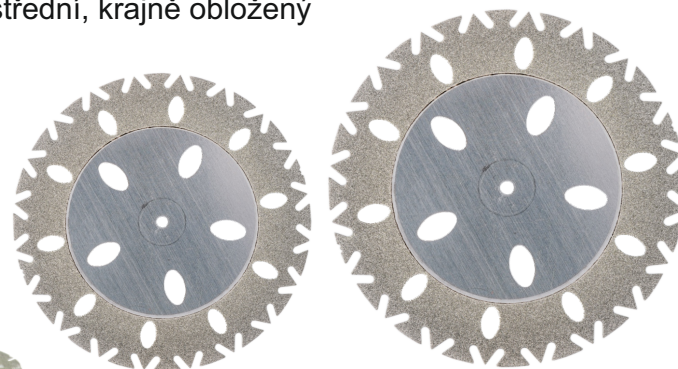

REF: 4963 4964

	L [mm]	0,30	0,30
	∅ [mm]	40,0	48,0
	obložení[mm]	7,5	9,0

806 104 333 524 400 480

20 000 min⁻¹

Galvanický diamant, separační disk na sádru
jemný, krajně obložený

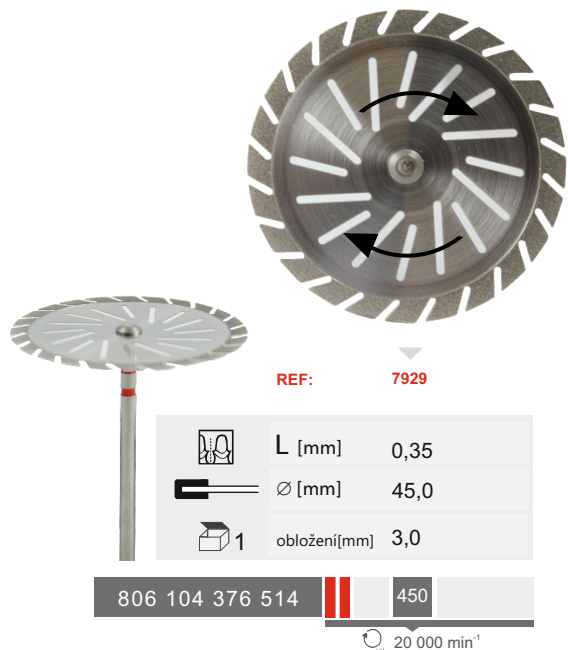

Galvanický diamant, separační disk na sádru
střední, krajně obložený



Galvanický diamant, separační disk na sádru
střední, krajně obložený





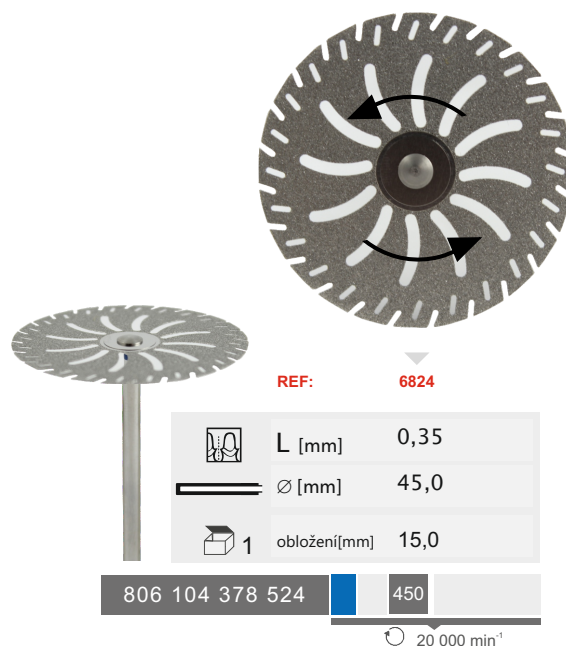

Galvanický diamant, separační disk na sádru
střední, celobložený



NOVINKA

Galvanický diamant, separační disk, extra jemný
Ultraflex, extra flexibilní



REF:	F406	F153	F152
 síla[mm]	0,12	0,12	0,12
 Ø [mm]	16,0	19,0	22,0
 obložení[mm]	4,0	4,0	5,0

806 104 505 504 160 190 220

20 000 min⁻¹



Galvanický diamant, separační disk, jemný
Ultraflex, extra flexibilní

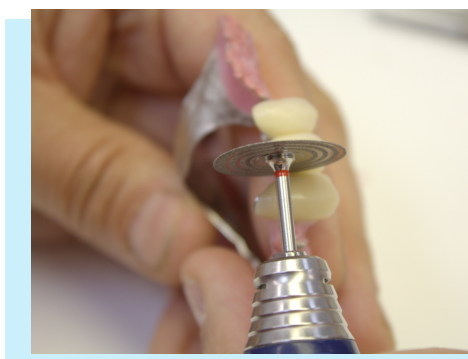

REF:	F151	F154
 síla[mm]	0,15	0,15
 Ø [mm]	19,0	22,0
 obložení[mm]	4,0	5,0

806 104 505 514 190 220

20 000 min⁻¹

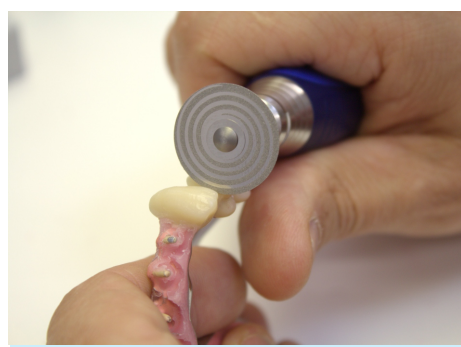

NOVINKA

Separáčn  disk na sádru
ljemn 

REF: **F507** **F508**

	L [mm]	0,3	0,3
	∅ [mm]	30,0	45,0
	obložen�[mm]	3,0	3,0

806 104 340 514 300 450

20 000 min⁻¹

Separáčn  disk na sádru
ljemn 

REF: **F506**

	L [mm]	0,3
	∅ [mm]	30,0
	obložen�[mm]	3,0

806 104 332 514 300

20 000 min⁻¹

Separáčn  disk, velmi jemn 
pln  oblo en 

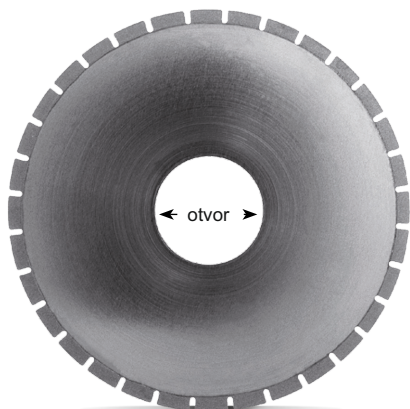

REF: 6825

	L [mm]	0,3
	∅ [mm]	80,0
	otvor [mm]	16,0

710 900 371 16

5 000 min⁻¹

Separáčn  disk, velmi jemn 
pln  oblo en 

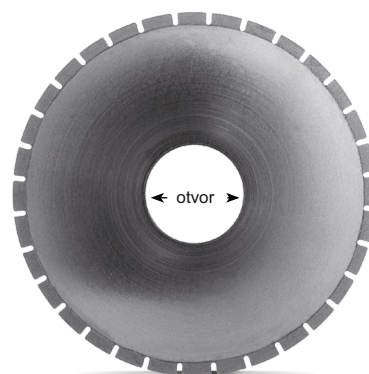

REF: 6826

	L [mm]	0,35
	∅ [mm]	75,0
	otvor [mm]	14,0

710 900 371 14

5 000 min⁻¹

Separáčn  disk, velmi jemn 
pln  oblo en 

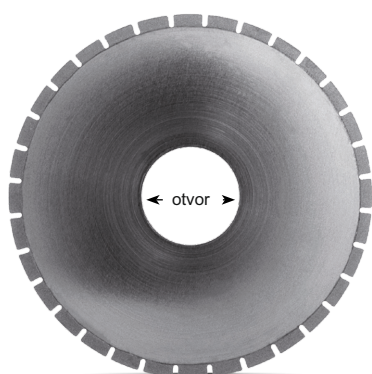

REF: 6827

	L [mm]	0,35
	∅ [mm]	75,0
	otvor [mm]	16,0

710 900 371 16

5 000 min⁻¹



Separáčn  disk, velmi jemn 
pln  oblo en 

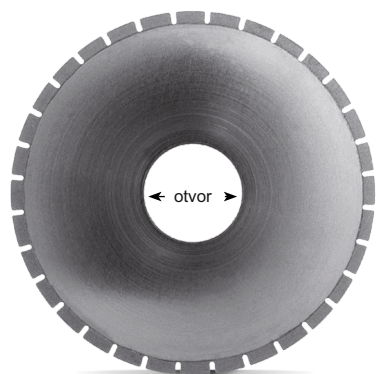

REF: 6829

	L [mm]	0,35
	∅ [mm]	75,0
	otvor [mm]	22,0

710 900 371 22

750

5 000 min⁻¹

Separáčn  disk, velmi jemn 
pln  oblo en 

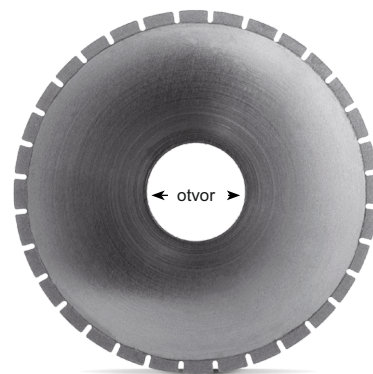

REF: 6828

	L [mm]	0,35
	∅ [mm]	75,0
	otvor [mm]	20,0

710 900 371 20

750

5 000 min⁻¹



Rotadent spol. s.r.o.

rotadent_czsk

info@rotadent.eu

+420 388 323 991

P-K-23-01